



ABSORBICA®-I 80

ABSORBICA®-Y 80

ABSORBICA®-I 150 FLEX

ABSORBICA®-Y 150 FLEX

Energy absorber with integrated lanyard
Absorbéur d'énergie avec longe intégrée

Traceability and markings
Traçabilité et marquage

CE 0082
APAVE Exploitation France SAS
6 Rue du Général Audran
92412 Courbevoie cedex - France
N°0082

Individual number / Numéro individuel
YY M 0000000 000
f. g. h. i.

Energy absorbing lanyards
in accordance with ANSI/ASSP
Z359.13-2013 and CSA Z259.11-17
Longes avec absorbéur d'énergie
conformes à l'ANSI/ASSP
Z359.13-2013 et CSA Z259.11-17

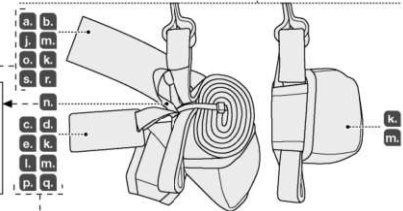
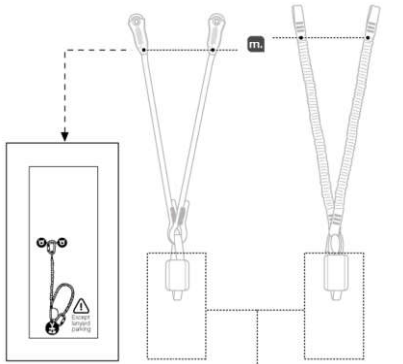

ABSORBICA-I 150 FLEX
ABSORBICA-Y 150 FLEX
ANSI / ASSP Z359.13
ABSORBICA



PETZL
ABSORBICA XXXXX
L0XXAA00
XXXXXXXXXXXX
CSA Z259.11 class XX
LONGUEUR MAX / MAX LENGTH:
EN: XXXm (XXXX)
ANSI / CSA: XXXm (90ft)

- Avoid contact with sharp edges
and abrasive surfaces
- Make only compatible connections
- Evitez les frottements sur des arêtes
tranchantes ou des matériaux abrasifs
- Respectez les connexions compatibles
Principal materials / Matériaux principaux:
polyester, nylon, PEHD

Warning: User Capacity Range 130-310 lbs.
12ft. 1350lbs.
Maximum Free Fall Average Arresting Force
Maximum Deployment Distance 60"
Forces may increase when cold and/or wet
Read Instructions Before Use

ABSORBICA-I 150 FLEX
ABSORBICA-Y 150 FLEX
CSA Z259.11
ABSORBICA



Read Instructions Before Use / Lire les instructions avant utilisation
Maximum Free-Fall Distance / Maximum de chute libre
3.6 m
12 ft
Maximum Deployment / Déploiement maximum
1.5 m (5ft)
Weight Range Including Tools / Gamme de poids incluant les outils
75-140 kg
165-310 lbs
Maximum Deployment Factor / Facteur de déploiement maximum
D₁₄₀ = 0.4
See User Instructions / Voir les instructions aux utilisateurs

ABSORBICA-I 150 FLEX
ABSORBICA-Y 150 FLEX
EN 355 : 2002
ABSORBICA
CE 0082
Weight range including tools / Gamme de poids incluant les outils **60 - 140 kg**
Maximum deployment / Déploiement maximum **1,61 m**
Maximum free-fall / Distance maximum de chute libre **4 m**

ABSORBICA-I 80
ABSORBICA-Y 80
EN 355 : 2002
ABSORBICA
CE 0082
Weight range including tools / Gamme de poids incluant les outils **60 - 140 kg**
Maximum deployment / Déploiement maximum **0,9 m**
Maximum free-fall / Distance maximum de chute libre **2 m**

ABSORBICA-I 150 FLEX
ABSORBICA-Y 150 FLEX
坠落制止用器具の規格適合
坠落制止用器具
第二种ショックアブソーバ
使用可能ワークスペース等設備適合 (60 - 140 kg)
ショックアブソーバの長さ 落下距離 (A)
≤ 1 m 3.9 m
1 m × x ≤ 1.83 m 6.26 m
1.83 m × x ≤ 2 m 6.6 m
最大自由落下距離 (B) 4 m

GB/T 24538-2009: II型
止坠器
缓冲器 II型
工作范围 (按工具) 60 - 140 kg
安全绳长度 最大自由落体距离 (A)
≤ 1 m 3.9 m
1 m × x ≤ 1.83 m 6.26 m
1.83 m × x ≤ 2 m 6.6 m
最大自由落体距离 (B) 4 m

WARNING / ATTENTION

Activities involving the use of this equipment are inherently dangerous. You are responsible for your own actions and decisions.
Before using this equipment, you must:
- Read and understand all instructions for Use.
- Get specific training in its proper use.
- Become acquainted with its capabilities and limitations.
- Understand and accept the risks involved.

Les activités impliquant l'utilisation de cet équipement sont par nature dangereuses. Vous êtes responsable de vos actes, de vos décisions et de votre sécurité.
Avant d'utiliser cet équipement, vous devez:
- Lire et comprendre toutes les instructions d'utilisation.
- Vous former spécifiquement à l'utilisation de cet équipement.
- Vous familiariser avec votre équipement, apprendre à connaître ses performances et ses limites.
- Comprendre et accepter les risques induits.

FAILURE TO HEED ANY OF THESE WARNINGS MAY RESULT IN SEVERE INJURY OR DEATH.

LE NON-RESPECT D'UN SEUL DE CES AVERTISSEMENTS PEUT ÊTRE LA CAUSE DE BLESSURES GRAVES OU MORTELLES.

1. Field of application (text part) Champ d'application (partie texte)

	Standards Normes	User weight range including the user's tools and clothing Gamme de poids utilisateur incluant les outils et les habits de l'utilisateur
ABSORBICA-I 80 (L011AB00)		
ABSORBICA-Y 80 (L012AB00)	EN 355: 2002	60 - 140 kg (130 - 310 lbs)
ABSORBICA-I 150 FLEX (L013AB01)	EN 355: 2002 PPE-R/11.074 V3 坠落制止用器具の規格	60 - 140 kg (130 - 310 lbs)
ABSORBICA-Y 150 FLEX (L014AB01)	GB/T 24538-2009: II型 ANSI/ASSP Z359.13-2013 12ft CSA Z259.11-17	75 - 140 kg (165 - 310 lbs)

PETZL.COM



Warning symbols
Panneaux d'alertes



PETZL
FR-38920 Crolles
Cdex 105A
PETZL.COM
ISO 9001 © 2023 Petzl Distribution
Tel: +33 (0)4 76 92 09 00

PETZL Sustaining our Community
Au service de la Communauté
Fondation **FONDATION-PETZL.ORG**

Distributed by:



2. Length
Longueur

ABSORBICA-I 80

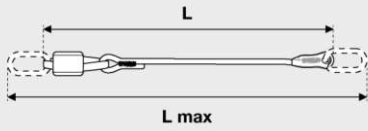

ABSORBICA-Y 80

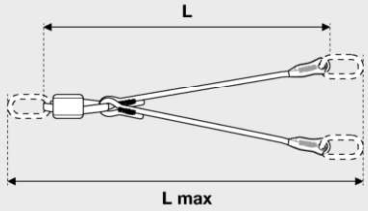

ABSORBICA-I 150 FLEX

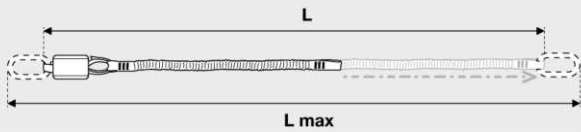

ABSORBICA-Y 150 FLEX

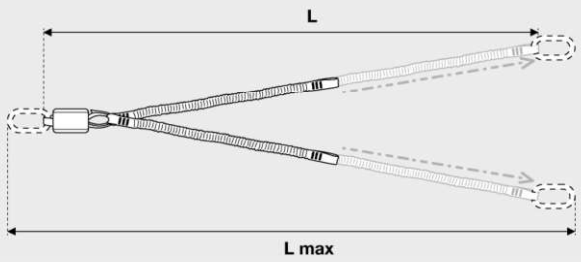

L	Lmax
0,7 m (2,3 ft)	1 m (3,28 ft)
0,7 m (2,3 ft)	1 m (3,28 ft)
1,53 m (5,02 ft)	<p>EN 355: 2002 墜落制止用器具の規格 GB/T 24538-2009: 型 II</p> <p>2 m (6,56 ft)</p> <hr/> <p>ANSI/ASSP Z359.13-2013 12 ft CSA Z259.11-17</p> <p>1,83 m (6 ft)</p>
1,53 m (5,02 ft)	<p>EN 355: 2002 墜落制止用器具の規格 GB/T 24538-2009: 型 II</p> <p>2 m (6,56 ft)</p> <hr/> <p>ANSI/ASSP Z359.13-2013 12 ft CSA Z259.11-17</p> <p>1,83 m (6 ft)</p>

3. Nomenclature

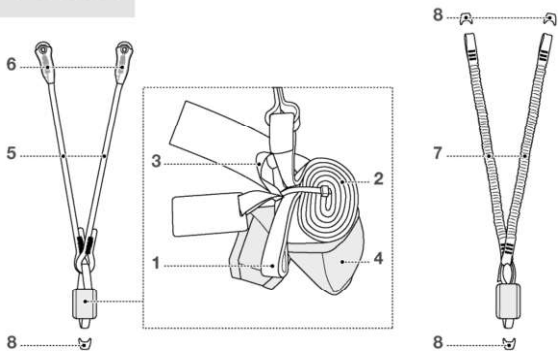

4. Inspection, points to verify
Contrôle, points à vérifier



PPE checking
Vérification EPI
PETZL.COM



Téléchargez l'application
Petzl pour faciliter
le contrôle de vos EPI :

Download the Petzl
application to facilitate
PPE inspections :

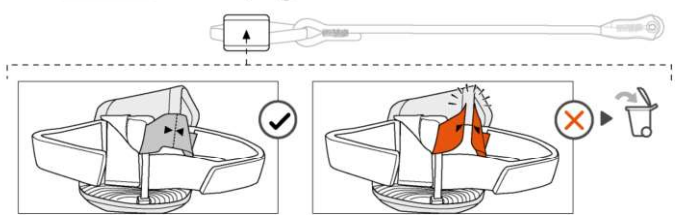

Distributed by:



5. Compatibility
Compatibilité

Frequent connections
Connexions fréquentes



or / ou



or / ou



Semi-permanent connection
Connexion semi-permanente

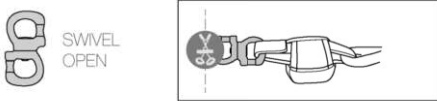

or / ou

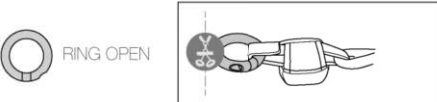

or / ou

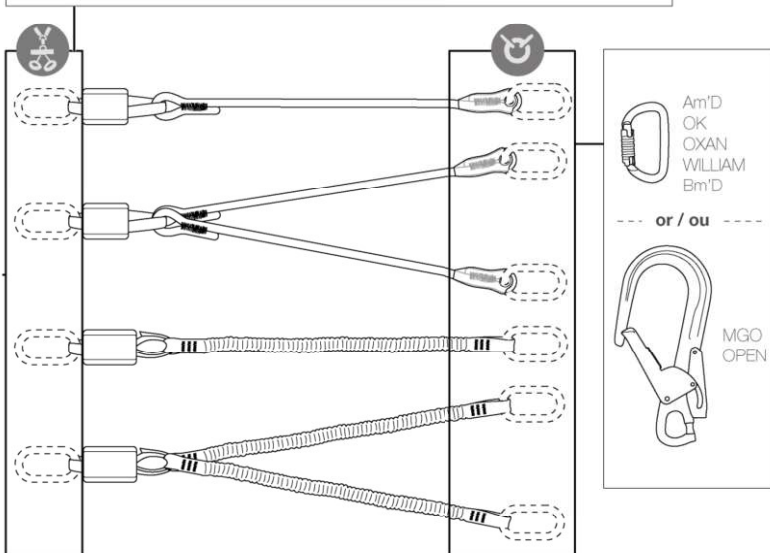
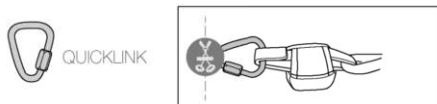

Standards / Normes

Standards / Normes	Connector Connecteur EN 362	Connector Connecteur ANSI + CAPTV	Connector Connecteur CSA	Connector Connecteur GB/T 23469
EN 355: 2002	✓	✗	✗	✗
ANSI/ASSP Z359.13-2013 12 ft	✗	✓	✗	✗
CSA Z259.11-17	✗	✗	✓	✗
墜落制止用器具の規格	✓	✓	✓	✗
GB/T 24538-2009: 型 II	✗	✗	✗	✓

Distributed by:



Distributed by:



Attachment to the harness
Connexion au harnais



or / ou



6. Preparation
Préparation

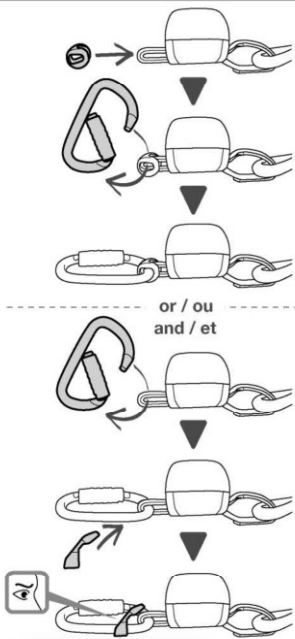

or / ou
and / et

Installing the connectors
Installation des connecteurs

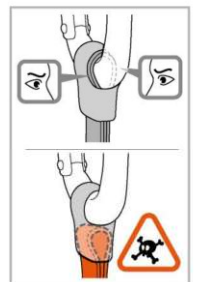
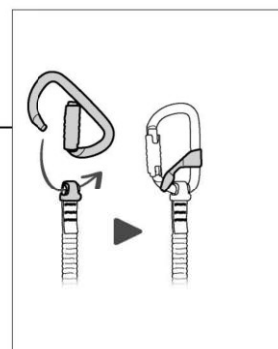
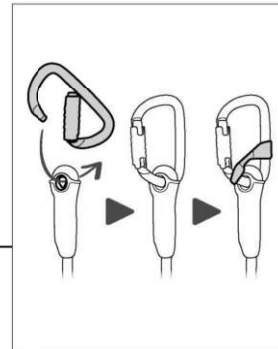
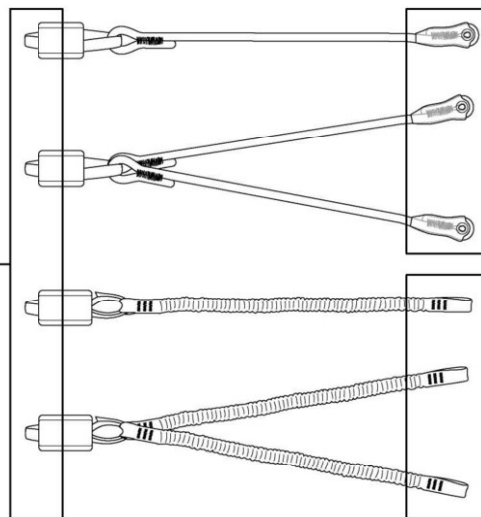

7. Working principle
Principe de fonctionnement

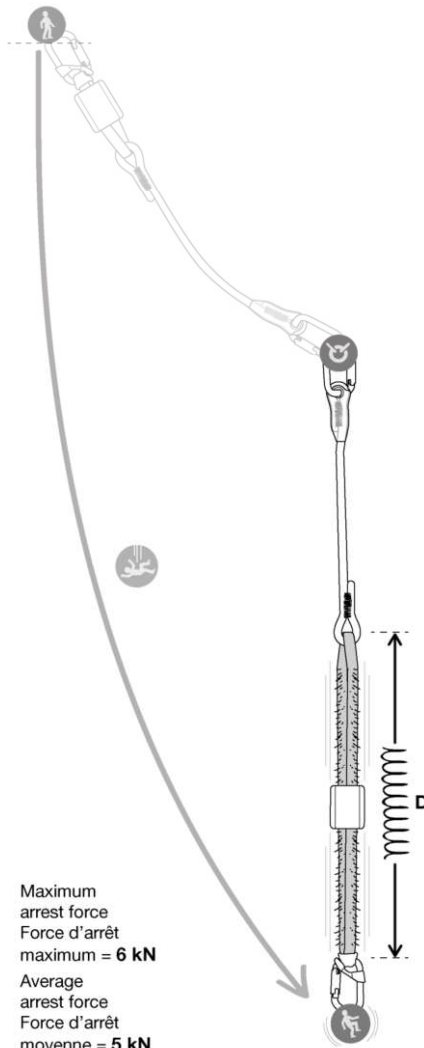

Maximum
arrest force
Force d'arrêt
maximum = **6 kN**
Average
arrest force
Force d'arrêt
moyenne = **5 kN**

Distributed by:



8. Performance

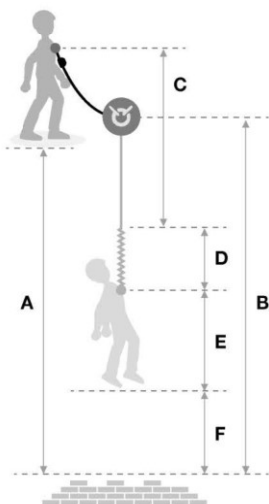

- A** = Clearance
Tirant d'air
- B** = Minimum anchor height
Hauteur mini de l'ancrage
- C** = Maximum free-fall distance
Hauteur maximum de chute libre
- D** = Deployment of the energy absorber
Déploiement de l'absorbeur d'énergie
- E** = Average user height
Taille moyenne de l'utilisateur (1.5 m/4.9 ft)
- F** = Safety margin
Marge de sûreté (1 m/3.28 ft)

For more information
Pour plus d'informations



ABSORBICA-I 80
ABSORBICA-Y 80
L max ≤ 1 m (3,28 ft)

A 3,58 m (11,75 ft)

3,87 m (12,70 ft)

B 4,08 m (13,39 ft)

4,37 m (14,34 ft)

C 2 m (6,56 ft)

2 m (6,56 ft)

D 0,58 m (1,90 ft)

0,87 m (2,85 ft)

ABSORBICA-I 150 FLEX
ABSORBICA-Y 150 FLEX
L max ≤ 1,83 m (6 ft)

A 5,57 m (18,27 ft)

6,06 m (19,88 ft)

B 5,24 m (17,19 ft)

5,73 m (18,80 ft)

C 3,66 m (12 ft)

3,66 m (12 ft)

D 0,91 m (2,99 ft)

1,40 m (4,59 ft)

ABSORBICA-I 150 FLEX
ABSORBICA-Y 150 FLEX
L max ≤ 2 m (6,56 ft)

A 5,98 m (19,62 ft)

6,42 m (21,06 ft)

B 5,48 m (17,98 ft)

5,92 m (19,42 ft)

C 4 m (13,12 ft)

4 m (13,12 ft)

D 0,98 m (3,22 ft)

1,42 m (4,66 ft)

Distributed by:



9. Precautions for use
Précautions d'utilisation

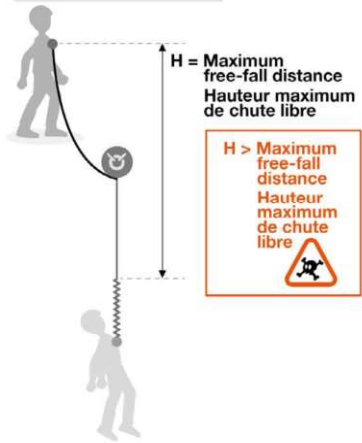

Travel along a horizontal traverse line and passing an intermediate anchor with ABSORBICA-Y
Déplacement sur main courante horizontale et passage d'un tracternement avec ABSORBICA-Y

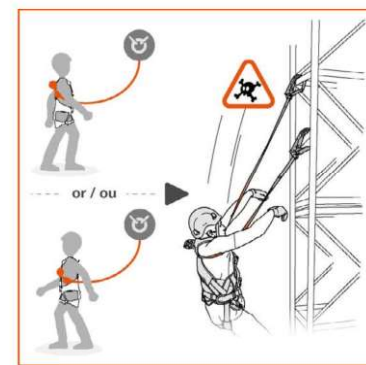
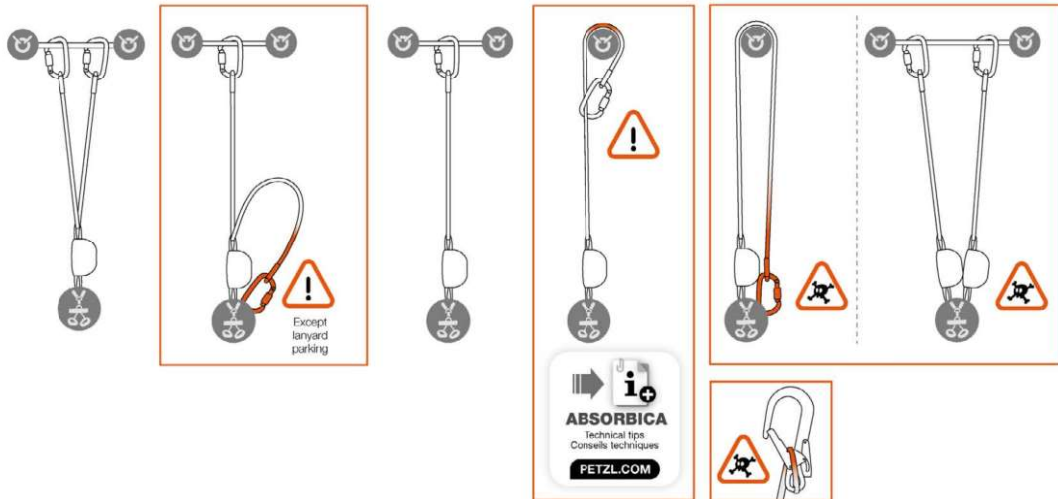
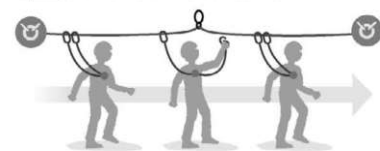

10. Additional information
Informations complémentaires

A. Lifetime / Durée de vie

Serial n° / N° de serie
XXXX XX XXXX + 10 years / ans

B. Markings / Marquage



C. Acceptable T° / T° tolérées

+50°C / +122°F
-30°C / -22°F

F. Drying / Séchage

+30°C maxi. / +86°F maxi.
Icons: sun, hair dryer, washing machine.

G. Storage - Transport / Stockage - transport



D. Precautions for use / Précautions d'usage



E. Cleaning - Disinfection / Nettoyage - Désinfection

+30°C maxi. / +86°F maxi.
Icons: washing machine, disinfectant bottle, and a crossed-out icon."/>

I. Modifications - Repairs / Modifications - Réparations



J. FAQ - Contact / Questions - Contact

petzl.com

Distributed by:



