



ABSORBICA®-Y 80 MGO EUR

ABSORBICA®-Y 80 MGO INT

ABSORBICA®-Y 150 FLEX MGO EUR

ABSORBICA®-Y 150 FLEX MGO INT

Energy absorber with integrated lanyards and MGO connectors
Absorbeur d'énergie avec longues intégrées et connecteurs MGO

Traceability and markings
Traçabilité et marquage

a. **b.** 0082

APAVE Exploitation France SAS
6 Rue du Général Audran
92412 Courbevoie cedex - France
N°0082

e. Individual number / Numéro individuel
YY M 0000000 000

f.
g.
h.
i.

o. Energy absorbing lanyards
in accordance with ANSI/ASSP
Z359.13-2013 and CSA Z259.11-17
Longes avec absorbeur d'énergie
conformes à l'ANSI/ASSP
Z359.13-2013 et CSA Z259.11-17

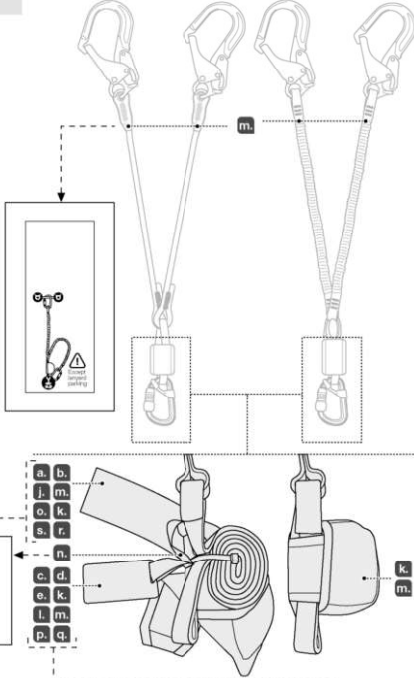

ABSORBICA-Y 80 MGO INT
ABSORBICA-Y 150 FLEX MGO INT

ANSI / ASSP Z359.13

ABSORBICA

**Warning: User Capacity Range 130-310 lbs.
12ft. 1350lbs.**
Maximum Free Fall Average Arresting Force
Maximum Deployment Distance 60"
Forces may increase when cold and/or wet
Read Instructions Before Use

ABSORBICA XXXXX
LOXXAA00
XXXXXXXXXXXXX
CSA Z259.11 class XX

LONGUEUR MAX / MAX LENGTH:
EN: 30,00 (3000)
ANSI / CSA: 30,00m (900ft)

ABSORBICA
PETZL PROTECTO Online
Order: 105A PETZL.COM

- Avoid contact with sharp edges and abrasive surfaces
- Make only compatible connections
- Évitez les frottements sur des arêtes tranchantes ou des matériaux abrasifs
- Respectez les connexions compatibles

Principal materials / Matériaux principaux : polyester, nylon, PCHD

ABSORBICA-Y 150 FLEX MGO INT

CSA Z259.11

ABSORBICA

Read Instructions Before Use / Lire les instructions avant utilisation

Maximum Free-Fall Distance Maximum de chute libre	Weight Range Including Tools Gamme de poids incluant les outils
3.6 m 12 ft	75-140 kg 165-310 lbs
Maximum Deployment Déploiement maximum	Maximum Deployment Factor Facteur de déploiement maximum
1.5 m (5 ft)	D = 0.4

See User Instructions
Voir les instructions aux utilisateurs

ABSORBICA-Y 80 MGO EUR
ABSORBICA-Y 80 MGO INT

EN 355 : 2002

ABSORBICA
CE 0082

Weight range including tools Gamme de poids incluant les outils	60 - 140 kg
Maximum deployment Déploiement maximum	0,9 m
Maximum free-fall Distance maximum de chute libre	2 m

ABSORBICA-Y 80 MGO INT
ABSORBICA-Y 150 FLEX MGO INT

墜落制止用器具の規格適合
墜落制止用器具
第二種ショックアブソーバ

使用可能 (A) - 最大落下距離 (A)	3.9 m
1 m < x ≤ 1.83 m	6.26 m
1.83 m < x ≤ 2 m	6.6 m
最大自由落下距離 (B)	4 m

ABSORBICA-Y 150 FLEX MGO EUR
ABSORBICA-Y 150 FLEX MGO INT

EN 355 : 2002

ABSORBICA
CE 0082

Weight range including tools Gamme de poids incluant les outils	60 - 140 kg
Maximum deployment Déploiement maximum	1,81 m
Maximum free-fall Distance maximum de chute libre	3,66 m

PPE-IV
11.074_V3

GB/T 24538-2009: II型

止坠器
缓冲器 II型

工作范围 (含工具)	60 - 140 kg
安全绳长度	最大自由落体 (A)
≤ 1 m	3.9 m
1 m < x ≤ 1.83 m	6.26 m
1.83 m < x ≤ 2 m	6.6 m
最大自由落体 (B)	4 m

WARNING / ATTENTION

Activities involving the use of this equipment are inherently dangerous. You are responsible for your own actions and decisions.

Before using this equipment, you must:

- Read and understand all Instructions for Use.
- Get specific training in its proper use.
- Become acquainted with its capabilities and limitations.
- Understand and accept the risks involved.

FAILURE TO HEED ANY OF THESE WARNINGS MAY RESULT IN SEVERE INJURY OR DEATH.

Les activités impliquant l'utilisation de cet équipement sont par nature dangereuses. Vous êtes responsable de vos actes, de vos décisions et de votre sécurité.

Avant d'utiliser cet équipement, vous devez :

- Lire et comprendre toutes les instructions d'utilisation.
- Vous former spécifiquement à l'utilisation de cet équipement.
- Vous familiariser avec votre équipement, apprendre à connaître ses performances et ses limites.
- Comprendre et accepter les risques induits.

LE NON-RESPECT D'UN SEUL DE CES AVERTISSEMENTS PEUT ÊTRE LA CAUSE DE BLESSURES GRAVES OU MORTELLES.

PETZL.COM

Latest version / Dernière version

Other languages / Autres langues

Technical tips / Conseils techniques

PPE checking / Fiche de contrôle EPI

Warning symbols / Panneaux d'alertes

(1) (2) (3) (4)

PETZL
FR-38920 Crolles
Cidex 105A
PETZL.COM
ISO 9001 © 2023 Petzl Distribution
Tel: +33 (0)4 76 92 09 00

Sustaining our Community
Au service de la Communauté
FONDATION-PETZL.ORG

Distributed by:



**1. Field of application (text part)
Champ d'application (partie texte)**

User weight range including the user's tools and clothing
Gamme de poids utilisateur incluant les outils et les habits de l'utilisateur

	Standards Normes	User weight range including the user's tools and clothing Gamme de poids utilisateur incluant les outils et les habits de l'utilisateur
ABSORBICA-Y 80 MGO EUR (L012CB00)	EN 355: 2002	60 - 140 kg (130 - 310 lbs)
ABSORBICA-Y 150 FLEX MGO EUR (L014CB01)	EN 355: 2002 PPE-R/11.074_V3	60 - 140 kg (130 - 310 lbs)
ABSORBICA-Y 80 MGO INT (L012BB00)	EN 355: 2002 墜落制止用器具の規格 GB/T 24538-2009: II 型 ANSI/ASSP Z359.13-2013 12ft	60 - 140 kg (130 - 310 lbs)
ABSORBICA-Y 150 FLEX MGO INT (L014BB01)	EN 355: 2002 PPE-R/11.074_V3 墜落制止用器具の規格 GB/T 24538-2009: II 型 ANSI/ASSP Z359.13-2013 12ft CSA Z259.11-17	60 - 140 kg (130 - 310 lbs) 75 - 140 kg (165 - 310 lbs)

3. Nomenclature

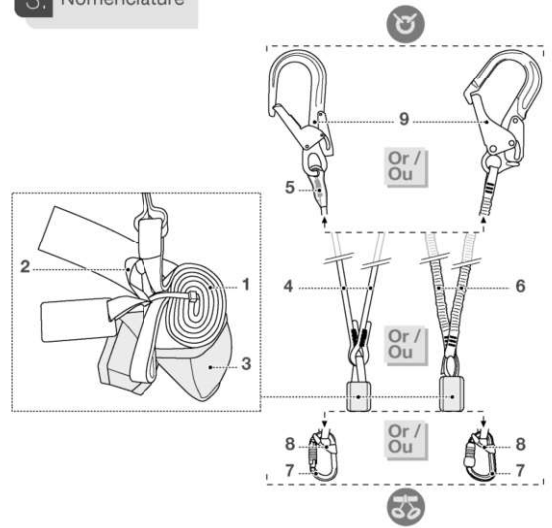

**2. Length
Longueur**

ABSORBICA-Y 80 MGO EUR

L = 1 m (3,28 ft)

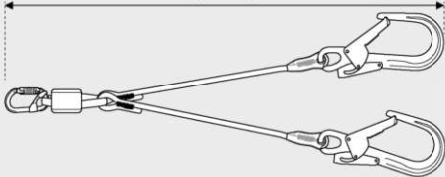

ABSORBICA-Y 80 MGO INT

L = 1 m (3,28 ft)

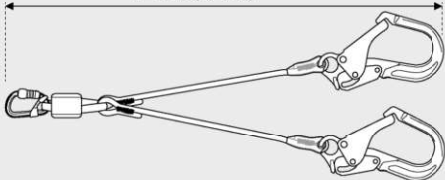

ABSORBICA-Y 150 FLEX MGO EUR

L = 1,83 m (6 ft)

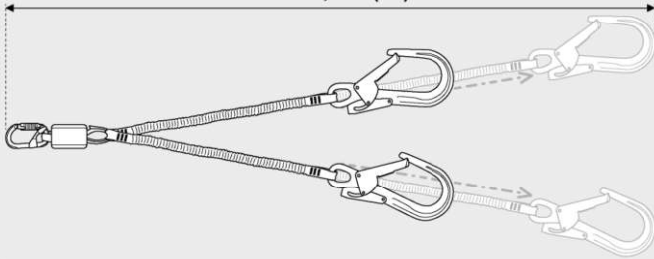

ABSORBICA-Y 150 FLEX MGO INT

L = 1,83 m (6 ft)

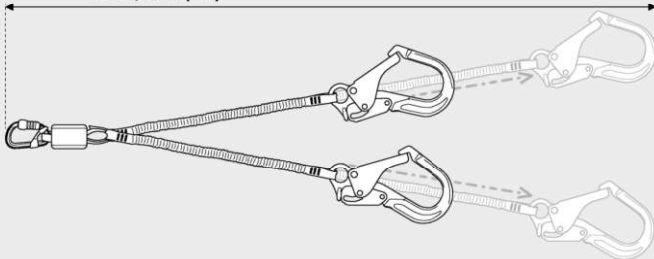

**4. Inspection, points to verify
Contrôle, points à vérifier**

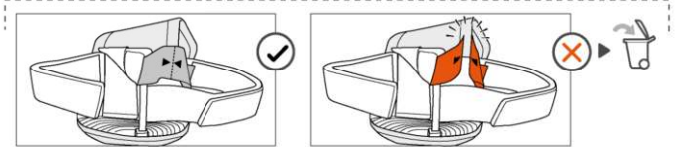
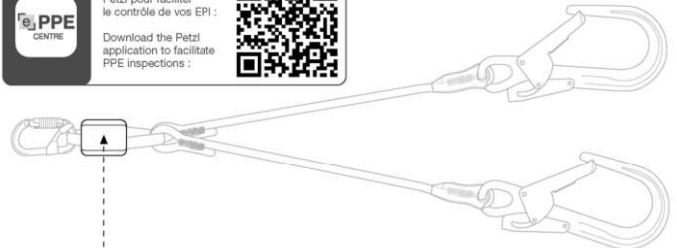

**5. Compatibility (text part)
Compatibilité (partie texte)**

**6. Preparation
Préparation**

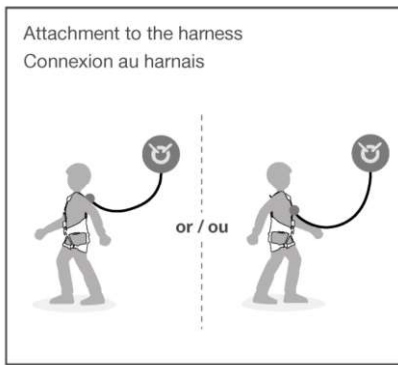

Distributed by:



7. Working Principle
Principe de fonctionnement

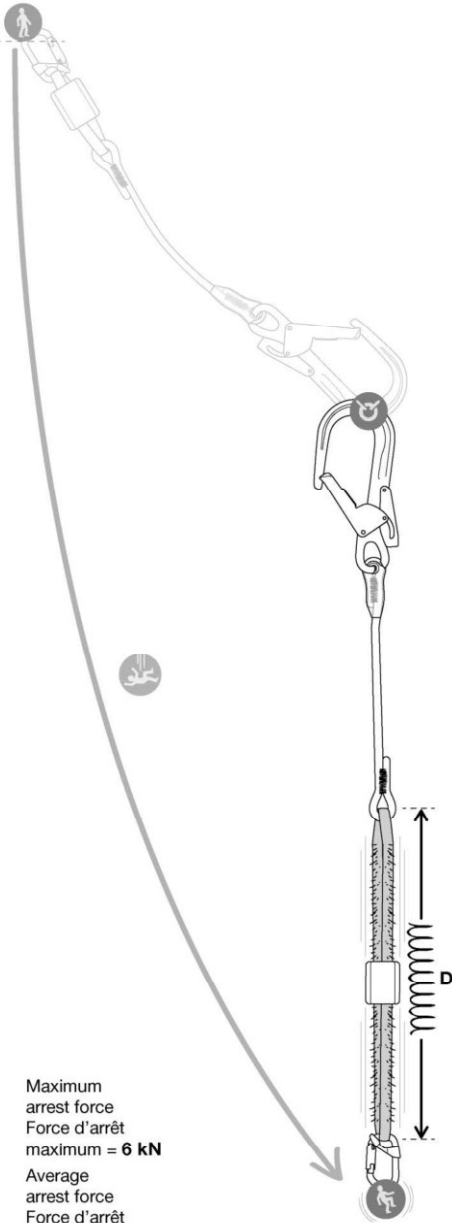

Maximum arrest force
Force d'arrêt maximum = **6 kN**
Average arrest force
Force d'arrêt moyenne = **5 kN**

8. Performance

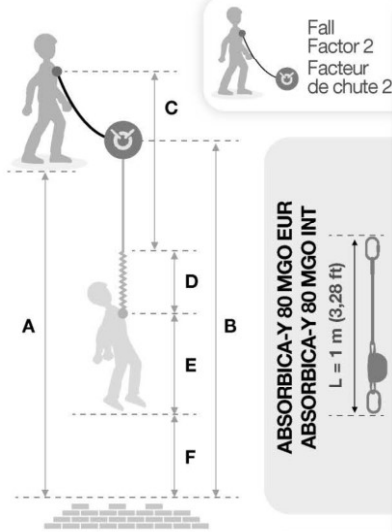



- A** = Clearance
Tirant d'air
- B** = Minimum anchor height
Hauteur mini de l'ancrage
- C** = Maximum free-fall distance
Hauteur maximum de chute libre
- D** = Deployment of the energy absorber
Déploiement de l'absorbeur d'énergie
- E** = Average user height
Taille moyenne de l'utilisateur
(1,5 m / 4,9 ft)
- F** = Safety margin
Marge de sûreté
(1 m / 3,28 ft)

ABSORBICA-Y 80 MGO EUR
ABSORBICA-Y 80 MGO INT



ABSORBICA-Y 150 FLEX MGO EUR
ABSORBICA-Y 150 FLEX MGO INT



	 ≤ 100 kg (220 lbs)	100 kg (220 lbs) <  ≤ 140 kg (310 lbs)
A	3,58 m (11,75 ft)	3,87 m (12,70 ft)
B	4,08 m (13,39 ft)	4,37 m (14,34 ft)
C	2,00 m (6,56 ft)	2 m (6,56 ft)
D	0,58 m (1,90 ft)	0,87 m (2,85 ft)
A	5,57 m (18,27 ft)	6,06 m (19,88 ft)
B	5,24 m (17,19 ft)	5,73 m (18,80 ft)
C	3,66 m (12 ft)	3,66 m (12 ft)
D	0,91 m (2,99 ft)	1,40 m (4,59 ft)

For more information
Pour plus d'informations



Distributed by:



9. Precautions for use
Précautions d'utilisation

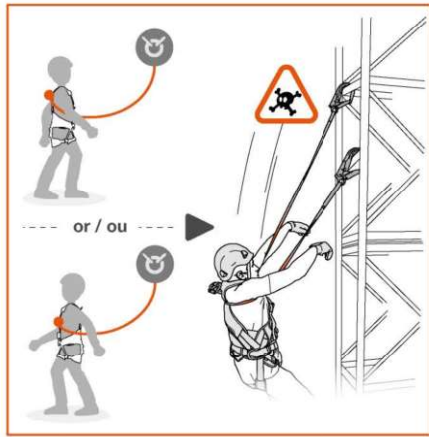

Travel along a horizontal traverse line and passing an intermediate anchor with ABSORBICA-Y
Déplacement sur main courante horizontale et passage d'un fractionnement avec ABSORBICA-Y

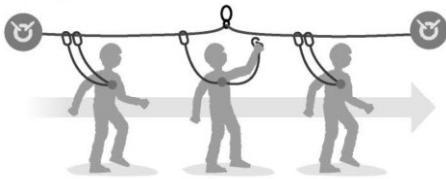

Distributed by:

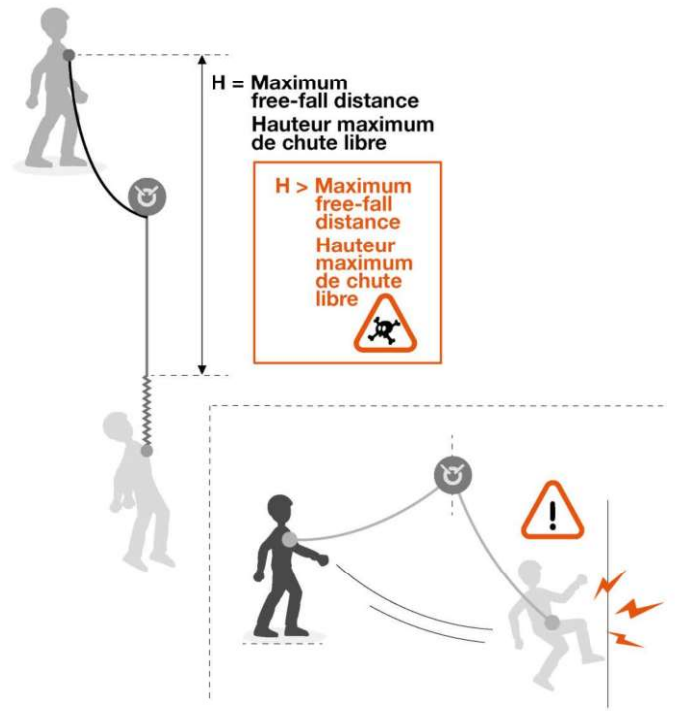

10. Additional information
Informations complémentaires

A. Lifetime / Durée de vie

Serial n° / N° de serie
 XXX XX XXXX + **10** years ans

B. Markings
Marquage



C. Acceptable T°
T° tolérées

 + 50°C / + 122°F
 - 30°C / - 22°F

D. Precautions for use / Précautions d'usage



E. Cleaning - Disinfection / Nettoyage - Désinfection



F. Drying / Séchage



G. Storage - Transport
Stockage - transport



I. Modifications - Repairs
Modifications - Réparations



J. FAQ - Contact
Questions - Contact



Distributed by:



